

Front Right Hand Shown

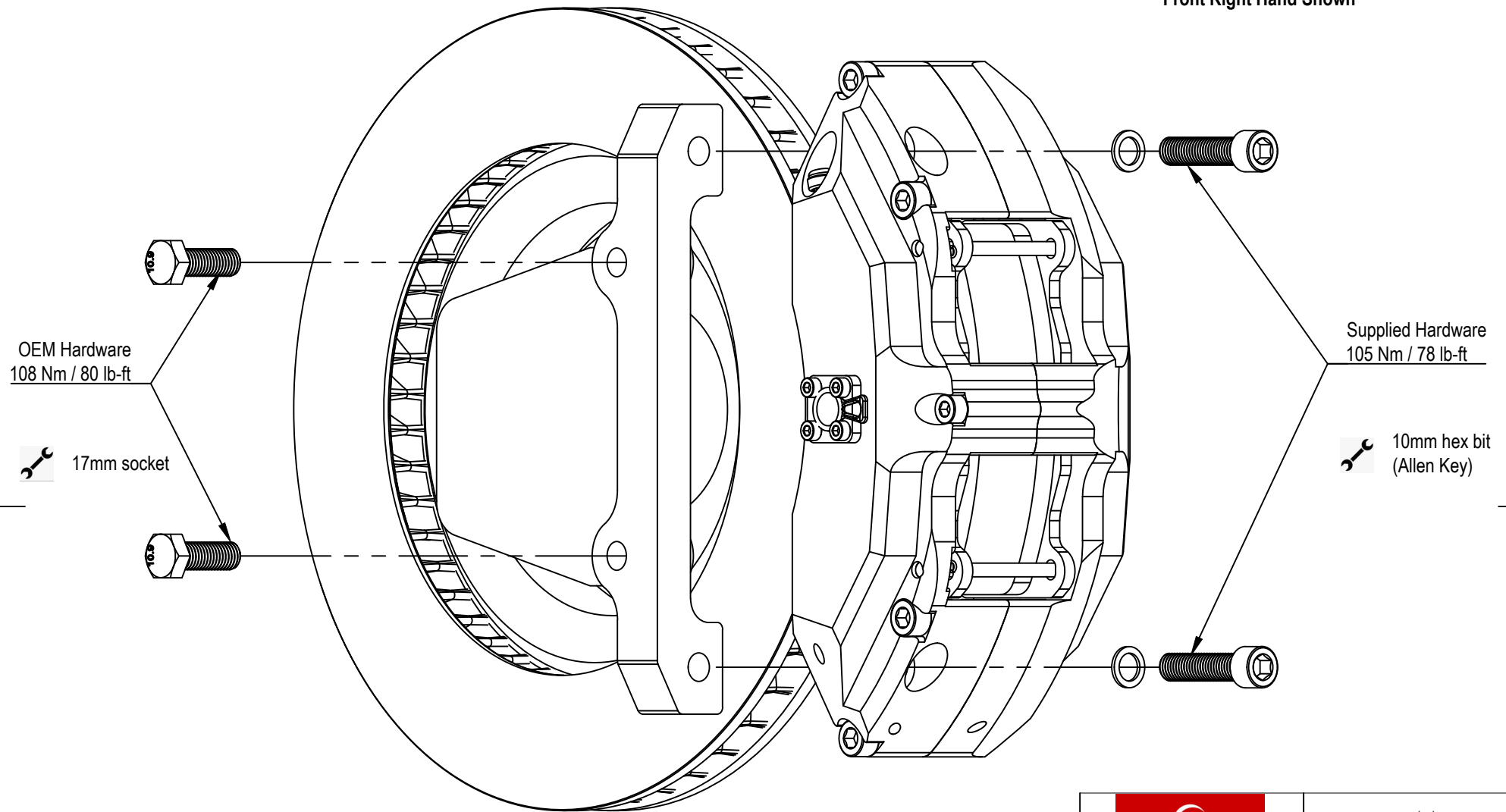

www.powerbrake.co.za
www.powerbrakeglobal.com

Assembly diagram for bracket orientation and torque specs

| | |
|----------------|-------------------------------------|
| DATE: | 2022/03/22 |
| VEHICLE: | Toyota Tacoma, FJ Cruiser, Lexus GX |
| KIT: | X6M / 350x34mm Stage-1 |
| PLATFORM CODE: | TOY01F |

Observe required torque specifications using an appropriate torque wrench / Do not use thread lockers on caliper mounting bolts

| Brake Pad Replacement Part Numbers | |
|---|--------------------------|
| Manufacturer | Part # |
| FMSI | D1116 |
| Powerbrake PB01 | 5001-PB01 |
| Powerbrake PB05 | 5001-PB05 |
| Endless | RCP112xx |
| G-Loc | GP1365 |
| Bendix Australia | DB1845U |
| Mintex | MDB3115 |
| Mintex (Alternative) | MDB3116 (lower friction) |
| Ferodo (Street) | FDB4212 or FDS4212 |
| Ferodo (Race) | FRP3100 |
| Hawk Performance | HB616x:607 |
| Hella Pagid (Street) | 8DB 355 019-521 |
| Pagid (Race) | 8005 |
| Febi Bilstein | 116138 |
| PFC | 9195 |

xx Designates manufacturer's friction compound. Select appropriate compound for application.
 Contact our Sales Office for more info if required.

| Spare Part Numbers | |
|------------------------------------|----------------|
| Description | Part # |
| Disc / Rotor Pair 350X34mm Stage-1 | AT482 |
| Caliper Seal Kit * | CSK-xx/xx/xx-O |

* xx/xx/xx refers to the piston sizes of your X-Line caliper - lasedered onto the inboard face of caliper body