

Front Right Hand Shown

5 x OEM disc bolt torque 74 Nm / 55 lb-ft

OEM Hardware  
123 Nm / 90 lb-ft

17mm socket

Supplied Hardware  
105 Nm / 78 lb-ft

10mm hex bit  
(Allen Key)

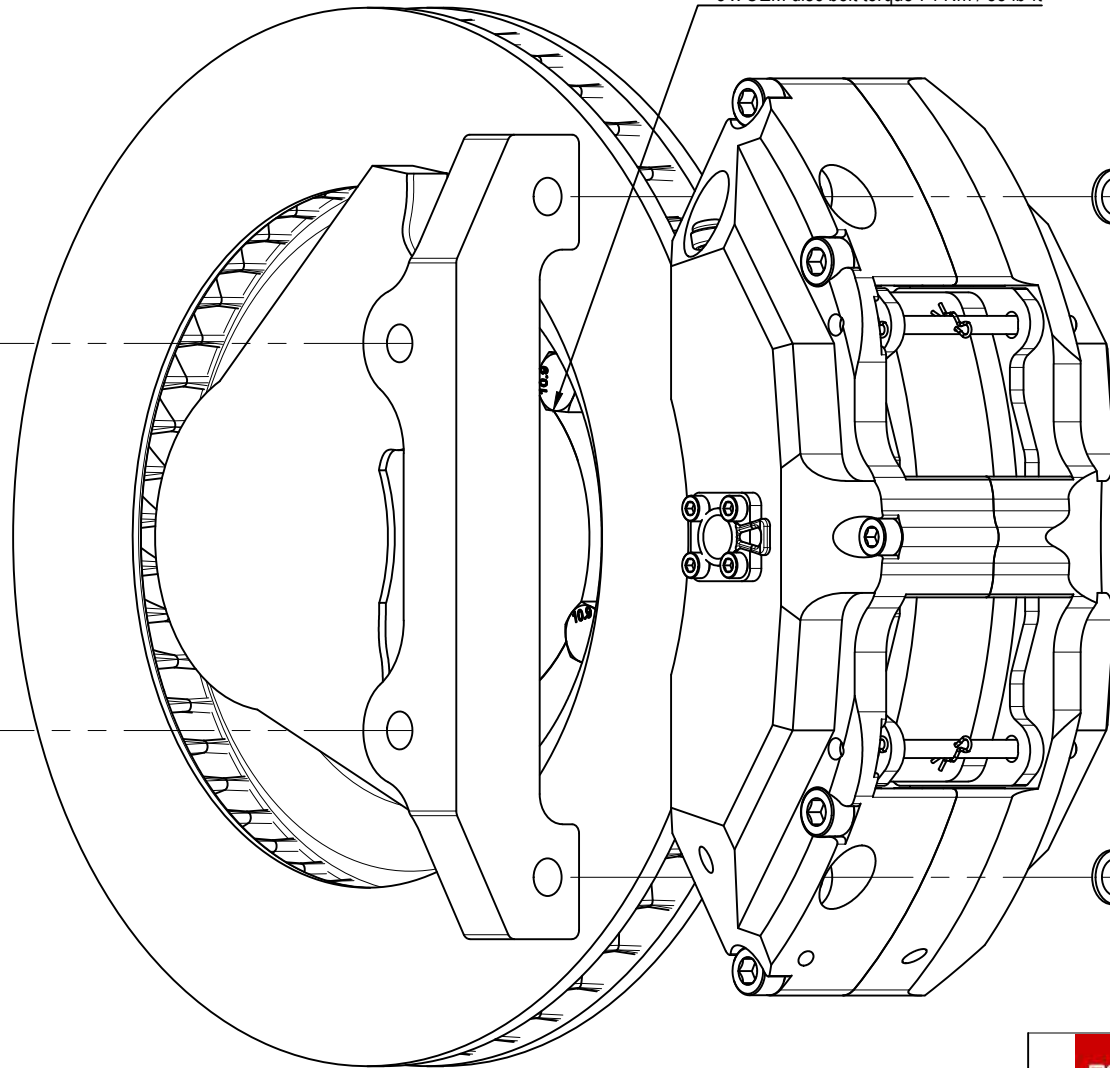

[www.powerbrake.co.za](http://www.powerbrake.co.za)  
[www.powerbrakeglobal.com](http://www.powerbrakeglobal.com)

Assembly diagram for bracket orientation and torque specs

DATE:	2023/04/12
VEHICLE:	Toyota Land Cruiser 100 Series
KIT:	X6M / 350x34mm Stage-1
PLATFORM CODE:	TOY15F

Observe required torque specifications using an appropriate torque wrench / Do not use thread lockers on caliper mounting bolts

### Brake Pad Replacement Part Numbers

Manufacturer	Part #
FMSI	D1116
Powerbrake PB01	5001-PB01
Powerbrake PB05	5001-PB05
Endless	RCP112xx
G-Loc	GP1365
Bendix Australia	DB1845U
Mintex	MDB3115
Mintex (Alternative)	MDB3116 (lower friction)
Ferodo (Street)	FDB4212 or FDS4212
Ferodo (Race)	FRP3100
Hawk Performance	HB616x.607
Hella Pagid (Street)	8DB 355 019-521
Pagid (Race)	8005
Febi Bilstein	116138
PFC	9195

*xx* Designates manufacturer's friction compound. Select appropriate compound for application.  
 Contact our Sales Office for more info if required.

### Spare Part Numbers

Description	Part #
Disc / Rotor Pair 350X34mm Stage-1	AT483
Caliper Seal Kit *	CSK-xx/xx/xx-O

\* xx/xx/xx refers to the piston sizes of your X-Line caliper - lasered onto the inboard face of caliper body